

"ADVANTEK" 180° WEAR PAD

All ADVANTEK Products
come complete with the
Adhesive necessary for
installation.

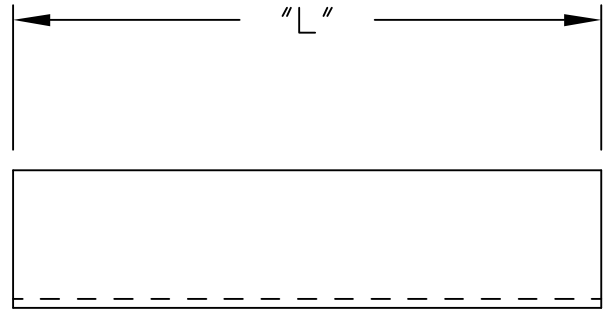

SIDE VIEW

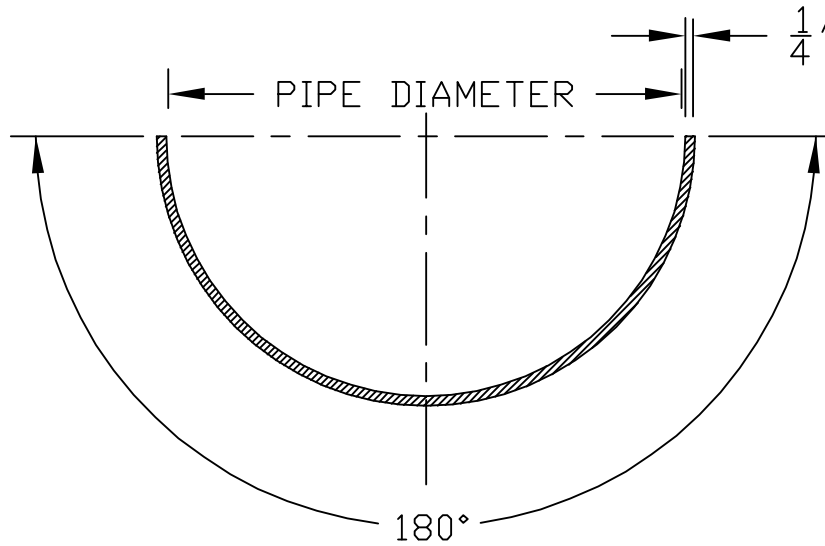

ORDER BY FIG. NO. B(NPS)-180(L)

NOTES:

1. RESIN TO BE DERAKANE 510C-350, WITH 3% ANTIMONY TRIOXIDE ADDED FOR CLASS 1 FLAME SPREAD RATING.
2. PIPE CLAMP LINER TO BE OF ALL-MAT CONSTRUCTION.
3. INSIDE SURFACE TO BE PRE-ROUGHENED FOR BONDING TO PIPE.
4. TO BE INSTALLED USING 2 PART STRUCTURAL EPOXY, MIXING NOZZLE & EPOXY APPLICATION GUN
5. MAXIMUM OPERATING TEMPERATURE -423°F - +350°F

REV. NO.	REVISION	BY	DATE	180° "ADVANTEK" WEAR PAD	
0	ISS. FOR CUST. COMMENT	TB	01/19/06	ADVANTAGE INDUSTRIAL SOLUTIONS	
				TEL (832)237-7500 - FAX (832)237-7501	
				FIGURE NO.	REV.
				B-180L	0